

# CUTTER MIXER FOOD PROCESSOR, 16 QT



CM-16

## FEATURES

- Polaris CM-16 Cutter Mixer is your go-to food processor for effortless preparation of hummus, sauces, dressings, mousses, ground spices, and pureed meals.
- With a 15-liter (16-qt) capacity, this heavy-duty processor operates at two speeds and ensures steady performance.
- The central opening on the lid allows easy addition of ingredients, while the stainless steel body enhances durability.
- All removable parts are dishwasher-friendly, making cleanup a breeze.
- Heavy duty construction
- 15-liter (16-qt) capacity
- Motor power: 1.7 kW
- Electrical: 208V / 3P / 5 A
- Gear transmission
- Two speed, 750 or 1,500 rpm.
- Bowl dimension (diameter/depth): 11.81" / 8.66"
- Safety interlocks.
- All stainless steel body, bowl, blades and accessories.
- Easy removable blade and bowl.
- Smooth quiet operation
- A high-heat and shock-resistant lid
- One-year limited parts & labor warranty (USA & Canada only).

## CUTTER MIXER FOOD PROCESSOR, 16 QT

**FRONT VIEW**

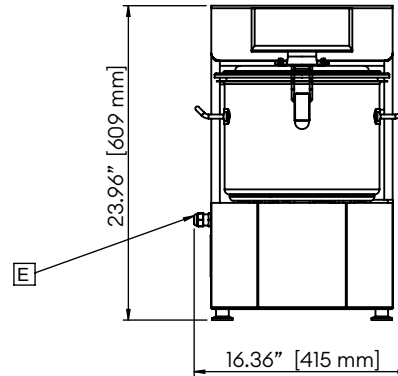

**SIDE VIEW**

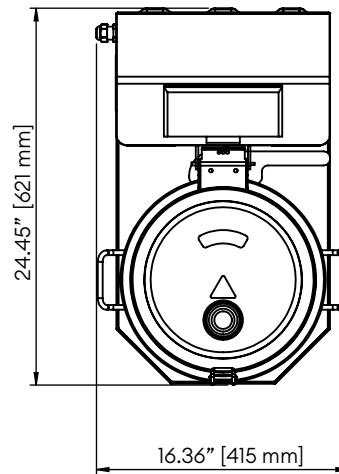

**TOP VIEW**

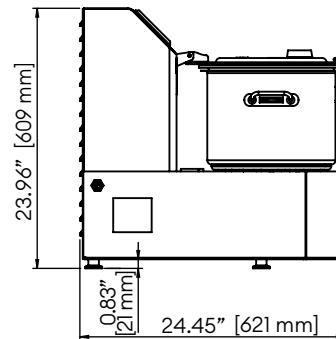

E: Electric Inlet  
1.7 KW / 208 V - 3P / 60 Hz

### TECHNICAL SPECIFICATIONS:

Model	Dimensions (W x H x D)	Capacity	Power	Electrical
CM-16	24.5" x 24" x 16.4" 621 x 609 x 415 mm	16 Qt	1.7 kW	208V/3P/4.7A

Galaxy Group reserves the right to modify specifications or discontinue models without incurring obligation.  
Dimensions are nominal.